

P1 01 PLAN VIEW: SB-215 CHECKOUT LEFT HAND SHOWN
SCALE: 3/8" = 1'-0"

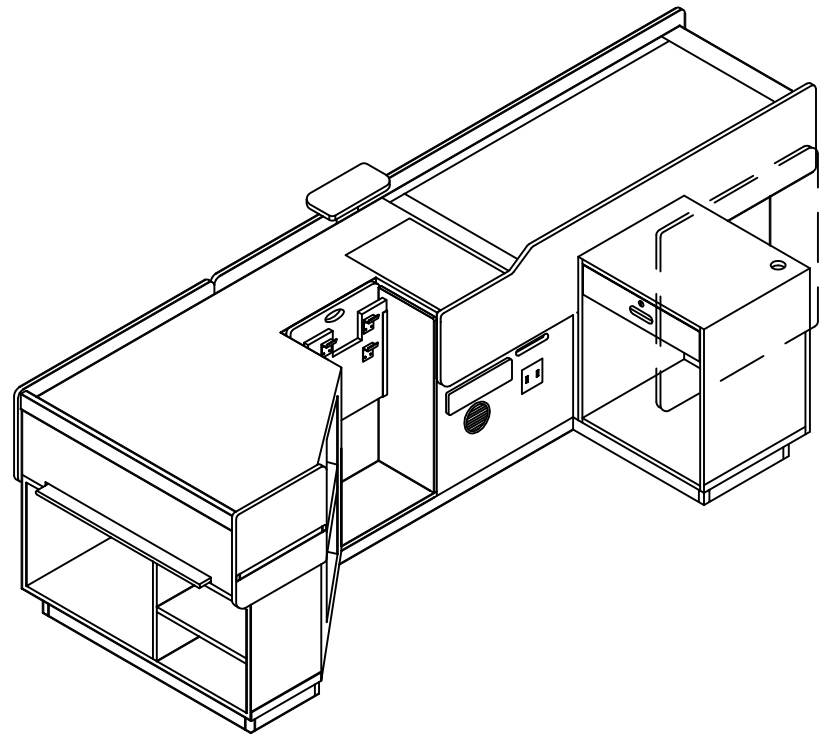

I1 01 ISOMETRIC VIEW: SB-215 CHECKOUT L/H SHOWN
SCALE: NOT TO SCALE

MODEL SB-215
SINGLE BELT LEFTHAND
CHECKSTAND

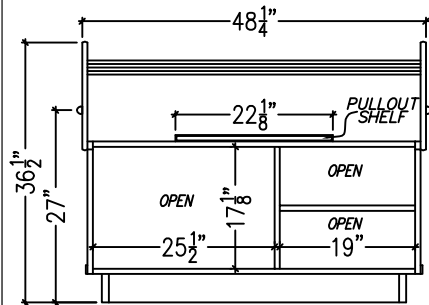

E1 01 END ELEVATION: SB-215 CHECKOUT L/H SHOWN
SCALE: 3/8" = 1'-0"

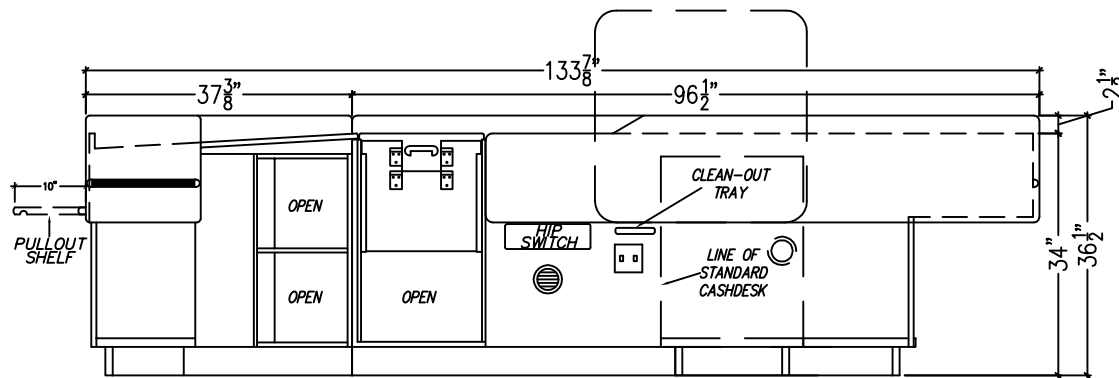

E2 01 INSIDE ELEVATION: SB-215 CHECKOUT L/H SHOWN
SCALE: 3/8" = 1'-0"



BEL-PAR INDUSTRIES LTD.

12160 - 103A Avenue
Surrey, B.C. Canada V3V 3G8
Ph (604) 581-5291 Fax (604) 581-3112

CUSTOMER:	
SB-215 L/H BELT CHECKOUT	
TITLE: PROMO SB-215 L/H	
DRAWN BY:	CAD FILE:
BEL-PAR	SB215-Standard-JAN
SCALE:	DATE:
1 1/2" = 1' 0"	JAN 2010
WORK ORDER:	SHEET NO.
	1